

JUBOFLEX® "S"

*** Torsional flexibility ** Radial flexibility *** Axial flexibility *** Conical flexibility

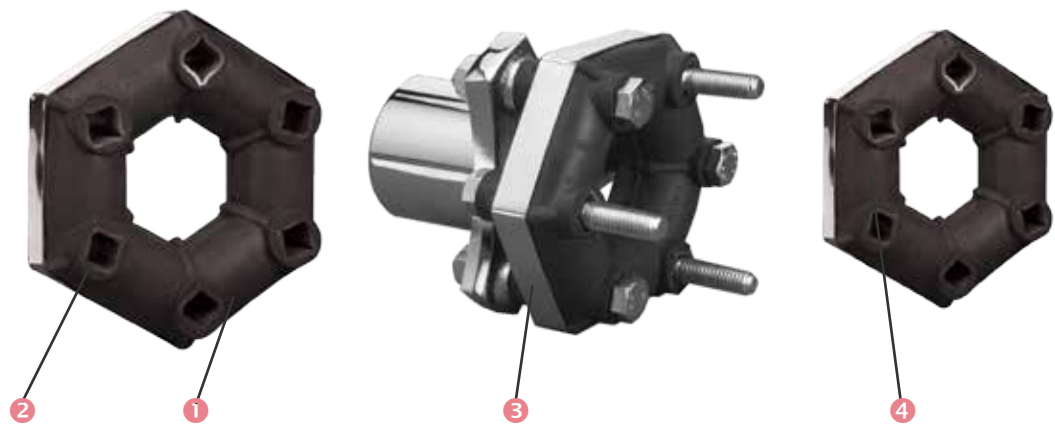

DESCRIPTION

- Flexible element
 - ① Precompressed natural rubber.
 - ② Bonded metal reinforcing mountings.
 - ③ Precompression band (to be removed after installation).
- Flange
 - ④ Die-cast steel (except 632267 which is cast-iron).

OPERATION

The JUBOFLEX «S» coupling is designed with the following features :

- radial disassembly without moving the machines that are coupled;
- the flexible element is compressed during assembly, which extends the range of operating conditions where the rubber is not subject to tension.

Advantages

- JUBOFLEX «S» has a greater load capacity than the standard JUBOFLEX.
- Highly effective attenuation of cyclic irregularities and peaks in the torque.
- Due to the precompression, the JUBOFLEX «S» has very good resistance to torsional peaks.
- Tolerance to large misalignment: avoids the need for precise alignment of the machines to be coupled.

Recommendation

- In use, precompression is achieved by the fixing bolts, and the JUBOFLEX «S» coupling operates without the precompression band round the flexible element.

DIMENSIONS

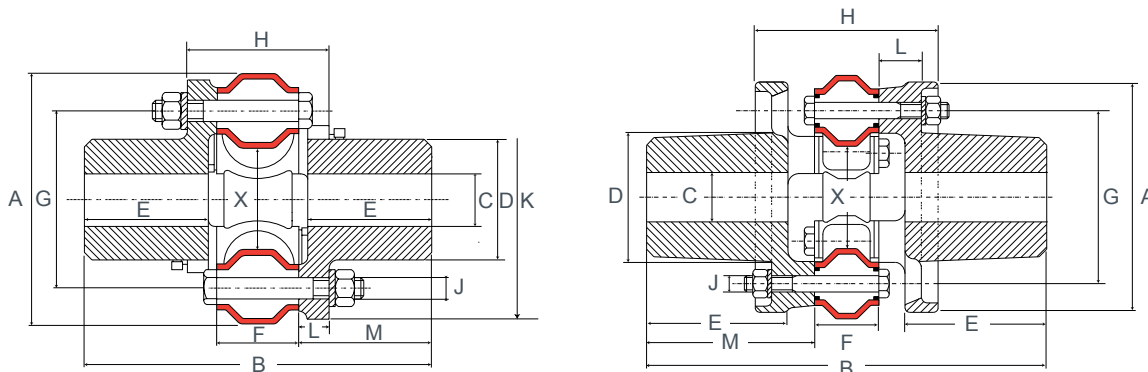

Flanges supplied unbores

JUBOFLEX Steel flanges except 632267

JUBOFLEX Cast-iron flanges : ref. 632267

Ref.	Nominal torque (N.m)	Vibrat. torque (N.m)	Max torque (N.m)	Max speed (rpm)	Hole size C (mm)		A (mm)	B (mm)	D (mm)	E (mm)	F (mm)	G (mm)	H (mm)	J (mm)	K (mm)	L (mm)	M (mm)	X* (mm)	Weight (kg)
					min	max													
632260	60	30	120	6 000		30	91	128	42	47	28	65	50	8	87	11	50	23	2
632261	130	65	270	5 000		40	117	172	56	66	32	85	60	10	113	14	70	35	3
632262	240	120	480	4 500		48	142	196	68	70	46	100	80	12	135	17	75	40	5
632263	370	185	750	3 500		60	181	247	90	93	51	132	93	14	172	21	98	63	12
632264	520	260	1 050	3 000		70	202	284	105	109	54	150	96	18	196	21	115	68	18
632265	750	375	1 500	2 800		75	232	322	115	124	62	170	108	20	225	23	130	75	25
632266	1 050	1 050	2 100	2 400		80	263	346	122	133	68	190	116	20	246	24	139	82	32
632267	1 800	1 800	3 600	2 400	60	100	280	486	156	172	78	210	222	20	-	52	204	110	57

* Diameter of passage in flexible element under the nominal torque.

Please see current price list for availability of items.

The maximum torque is considered to be an infrequent start-up torque and is not periodic.

PARTS LIST

The flexible elements are delivered precompressed using a precompression band which should be removed after installation.

Coupling without protector	Flexible element		Flange	
	Reference	Qty	Reference	Qty
632260	632550	1	321314	2
632261	632551	1	321324	2
632262	632552	1	321334	2
632263	632553	1	321344	2

Coupling without protector	Flexible element		Flange	
	Reference	Qty	Reference	Qty
632264	632554	1	321354	2
632265	632555	1	321374	2
632266	632556	1	321364	2
632267	632557*	1	321390	2

* Cet élément a 8 trous de fixation.

OPERATING CHARACTERISTICS

Coupling Reference	Nominal torque (N.m)	Vibratory coupling (N.m)	Torsion under NT (degrees)	Stiffness			
				Axial (Dan/Mm)	Radial (Dan/Mm)	Torsional (M.kn/Rad.)	Conical (M.kn/Rad.)
632260	60	30	8	9	30	0.43	0.63
632261	130	65	8	11.6	4.3	0.8	0.08
632262	240	120	8	16.5	67.5	1.72	0.22
632263	370	185	7	14.8	44.4	3.15	0.85
632264	520	260	7	14.9	44.6	4.11	-
632265	750	375	7	18	45	6.5	0.86